

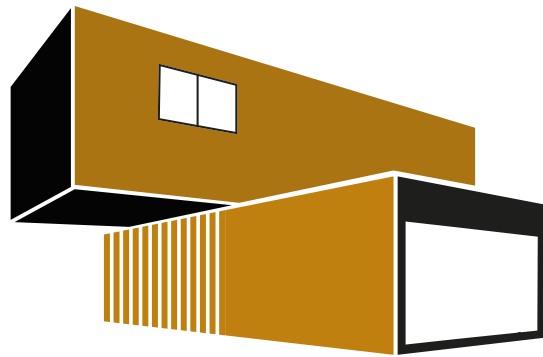

Créateur d'espaces modulaires

depuis 1987

Édition 2022



MODULE HOUSE

by  **ESW**

■ PRÉSENTATION

Depuis plus de 35 ans, ESW met son savoir-faire et son expertise au service de ses clients pour répondre aux mieux à leurs exigences.

ESW développe des solutions innovantes pour répondre de la manière la plus personnalisée aux besoins de ses partenaires.

Aujourd'hui, grâce à votre confiance, nous sommes le Leader fabricant et créateur des espaces et bâtiments modulaires en Tunisie.

■ PRESENTATION

For more than 35 years, ESW put his knowledge and expertise at the service of its customers to meet to best their requirements.

ESW develops innovative solutions to respond in the most personalized way to the needs of its partners.

Today, thanks to your trust, we are the leading manufacturer and creator of modular spaces and buildings in Tunisia.

+35^{ans}
d'expérience

**CONCEPTEUR-
FABRICANT
DE MODULAIRES
DEPUIS 1987**

LEADER
DE LA CONSTRUCTION
**MODULAIRE
EN TUNISIE**

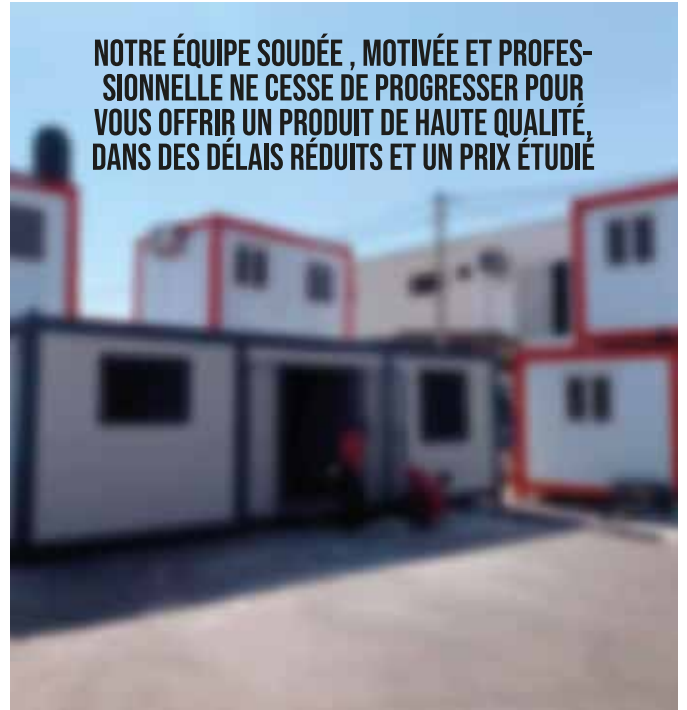

**NOTRE ÉQUIPE SOUDÉE , MOTIVÉE ET PROFES-
SIONNELLE NE CESSE DE PROGRESSER POUR
VOUS OFFRIR UN PRODUIT DE HAUTE QUALITÉ,
DANS DES DÉLAIS RÉDUITS ET UN PRIX ÉTUDIÉ**



Créateur d'espaces modulaires

**PENSEZ CONSTRUCTION MODULAIRE DÉS LE DEBUT DE VOTRE PROJET
VOUS SEREZ SURPRIS DE CE QUE NOUS POUVONS FAIRE**



RAPIDE



MODULARITÉ



ÉCONOMIQUE









ÉCOLOGIQUE



ÉVOLUTIF



FLEXIBILITÉ

01		House MODULE	06
02		Work MODULE	12
03		Security MODULE	16
04		Education MODULE	20
05		Event MODULE	24
06		Storage MODULE	28
07		Terrasse MODULE	32

NOS GAMMES



.01

MODULE
HOUSE





Découvrez nos maisons préfabriquées :
des logements temporaires ou permanents
clé en main
ESW réinvente une solution modulaire
pour un habitat chaleureux, moderne et
écologique.

Discover our prefabricated houses :
temporary or permanent turnkey
housing
ESW reinvents a modular solution for a
warm, modern and ecological house.

► **Possibilités d'utilisation :**

Bungalow, maison de campagne, studio
de jardin, extension de maison





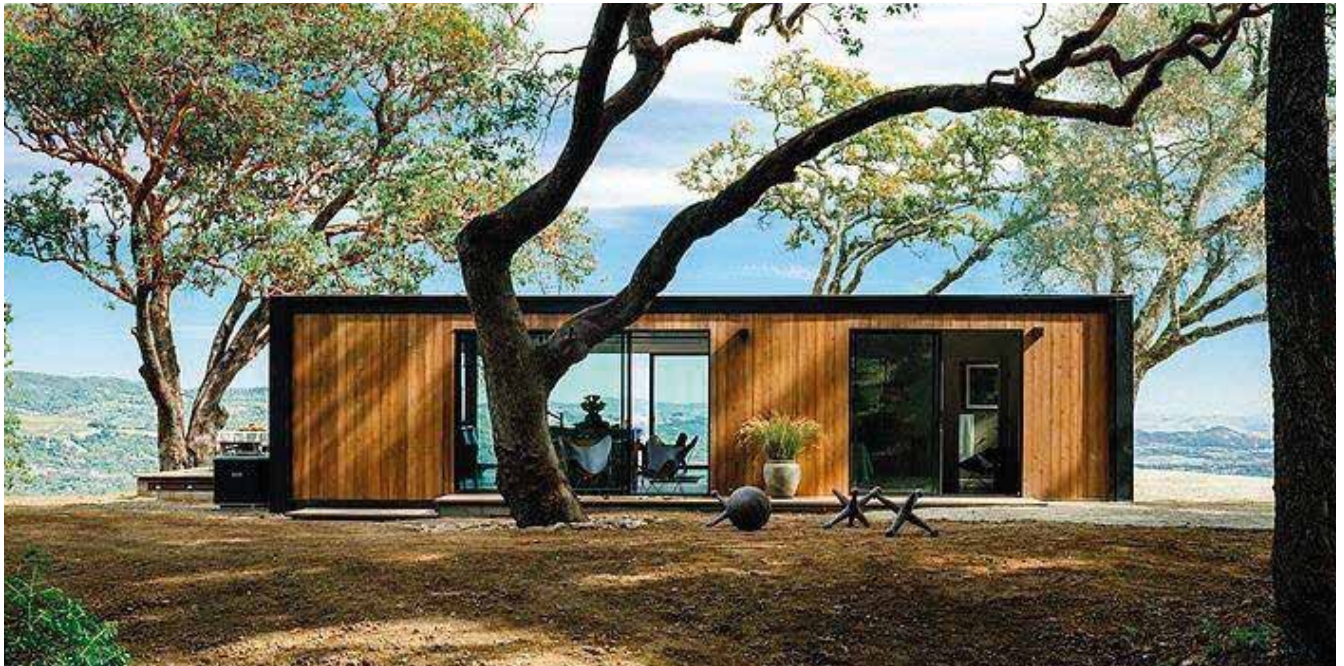



S+0 / 18 m²



S+1 / 21 m²



S+2 / 45 m²



S+3 / 72 m²



S+1 / 27m²



S+2 / 36m²



.01

WORK
MODULE





Du bureau simple et fonctionnel jusqu'au grand open-space pour toute une équipe.

Nos constructions modulaires vous permettent d'associer rapidité et qualité de réalisation pour bénéficier d'une solution de bureau durable et économique.

From simple and functional office to large open-space for a whole team. Our modular constructions allow you to associate speed and quality of realization to benefit from a durable and economic office solution

► **Possibilités d'utilisation :**

Bureau de chantier, point de vente, showroom, bloc sanitaire, open space, agence de banque, réfectoire...





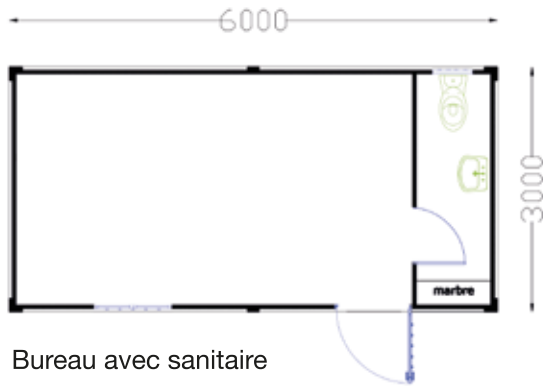

Bureau avec sanitaire

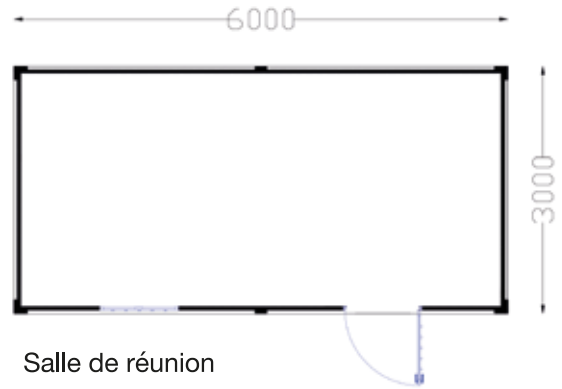

Salle de réunion

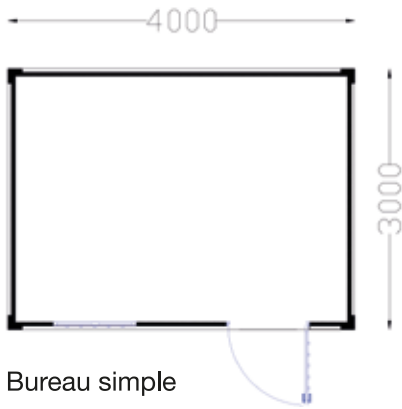

Bureau simple

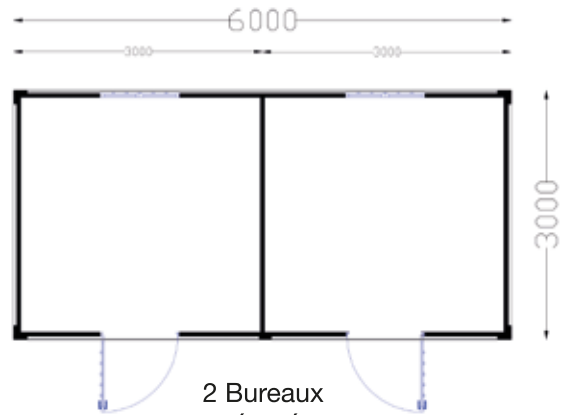

2 Bureaux
séparés

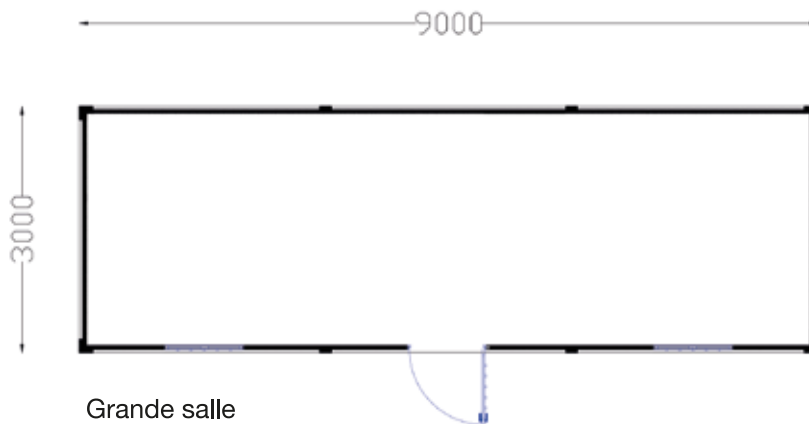

Grande salle



.02

SECURITY
MODULE





Besoin de surveillez votre local et contrôlez les accès ? Vous voulez mettre votre agent de sécurité à l'abri ? Nos guérites préfabriquées présentent la solution parfaite pour tous vos besoins des locaux de sécurité.

Need to survey your site and control the access? Do you want to put your security guard in cover?

Our prefabricated booths are the perfect solution for all your security needs.

► **Possibilités d'utilisation :**

guérite, poste de garde, point de contrôle, bureau d'accès, loge gardien ...





Guérite simple

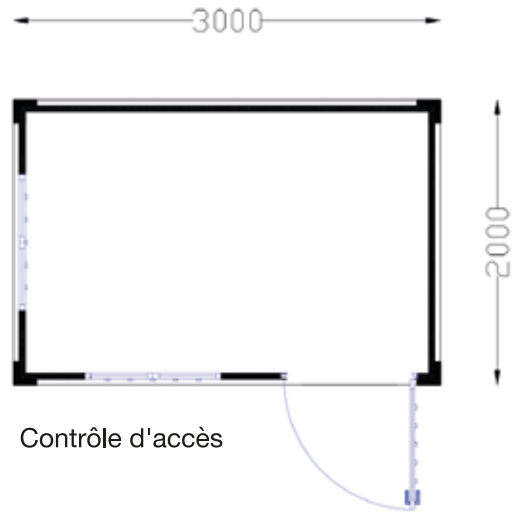

Contrôle d'accès

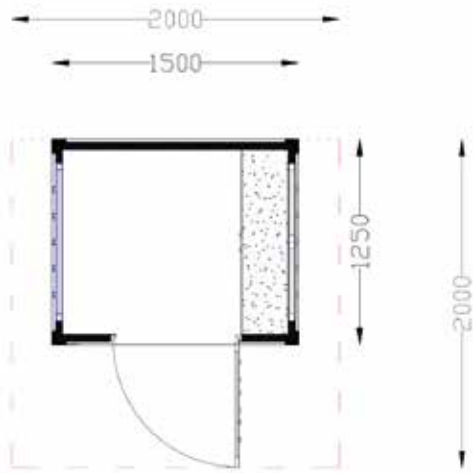

Guérite avec toiture chinoise

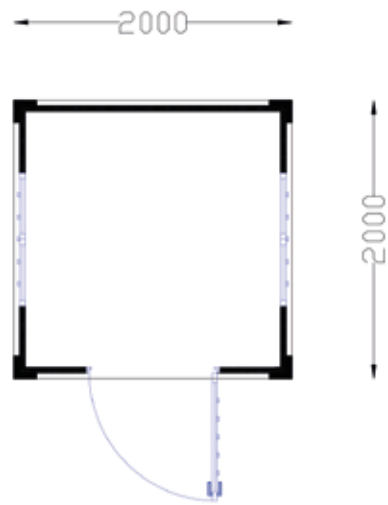

Loge gardien



.03

EDUCATION
MODULE





Votre établissement scolaire a une petite capacité ?
Besoin d'ajouter des salles de classe à votre école ?
Vous voulez créer votre local scolaire ?
ESW présentent la solution optimale, rapide et efficace pour répondre à la demande croissante des inscriptions et accueillir les élèves dans de bonnes conditions.

Your school has a small capacity?
Need to add classrooms to your school?
You want to create your school premises?
ESW presents the optimal, fast and efficient solution to meet the growing demand for registration and to welcome students in good conditions

► **Possibilités d'utilisation :**

salle de classes, salle de formation, crèche, administration, bloc sanitaire, buvette, salle de lecture ...





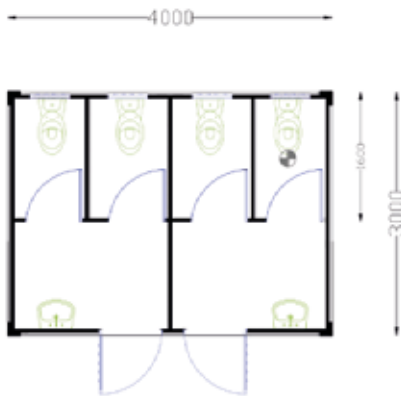

Sanitaire quadrupel

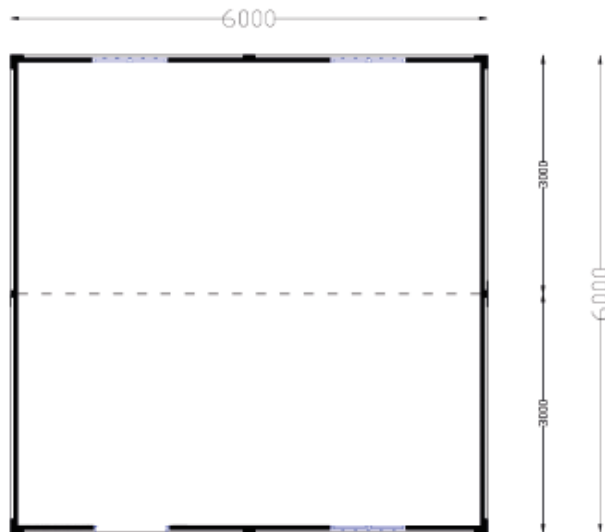

Salle de classe 36 m²

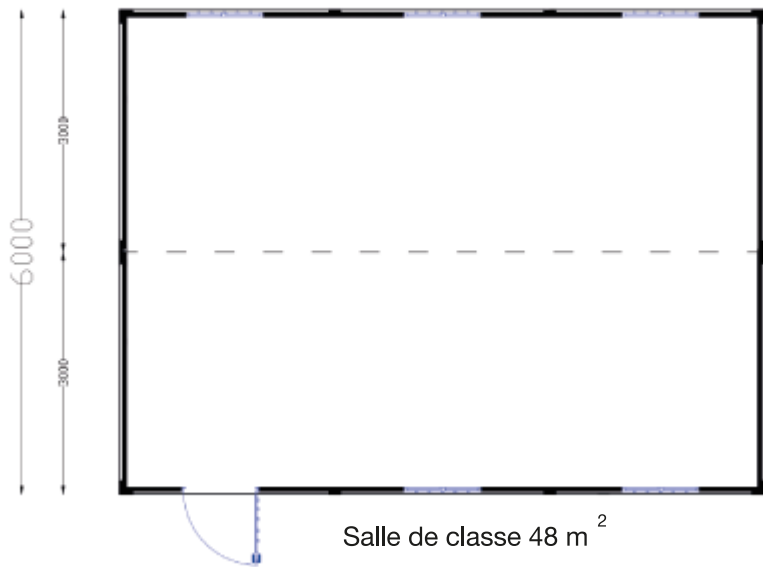

Salle de classe 48 m²

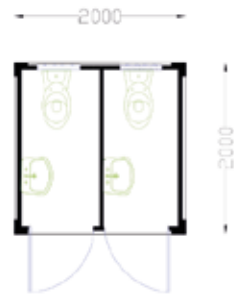

Sanitaire double



.04

EVENT
MODULE





Besoin d'un point de vente, showroom, boutique, stand ou bloc sanitaire transportable, flexible et rapide ? ESW vous accompagne dès la réalisation de votre événement en tenant compte des contraintes d'espace, de temps et de budget de vos manifestations.

Need a showroom, shop, stand or sanitary block transportable, flexible and fast? ESW accompanies you from the realization of your event taking into account the constraints of space, time and budget.

► **Possibilités d'utilisation :**
Point de vente, stand d'exposition, boutique, billetterie, sanitaire pour événement, guichet de renseignement ...





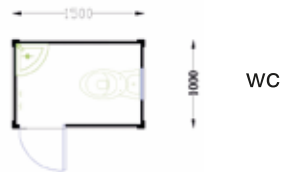
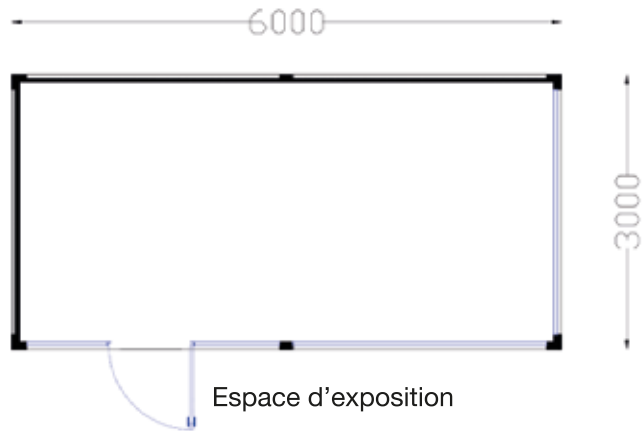
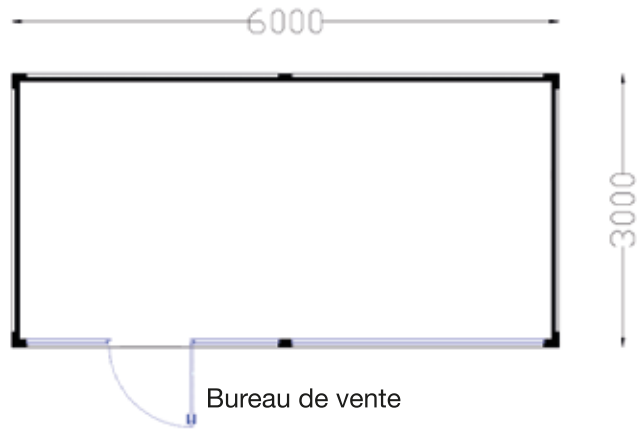



.06

STORAGE
MODULE





Pour mettre à l'abri votre matériel ou arranger votre équipement sur une période ponctuelle ou pérenne, ESW vous propose des modules sécurisés, secs et propres.

To protect or arrange your equipment for a specific or perennial period, ESW offers to you secure, dry and clean modules.

► Possibilités d'utilisation :
stockage matériel, garage, atelier, local
de rangement ...



Rangement archive

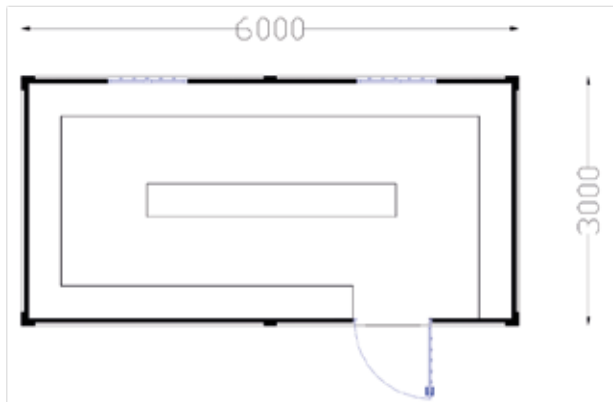

Garage avec placard

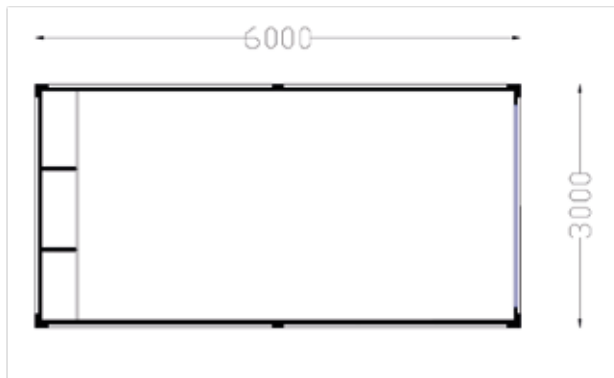

Garage

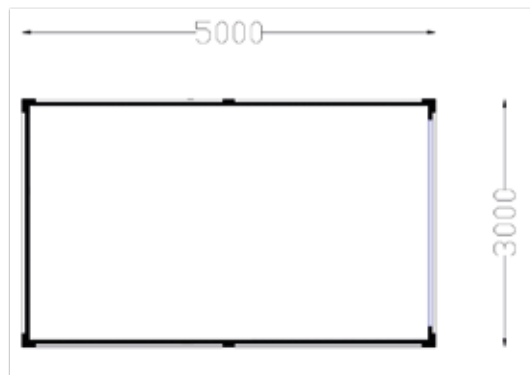



.05

TERRASE
MODULE





Besoin d'un point de vente, showroom, boutique, stand ou bloc sanitaire transportable, flexible et rapide ? ESW vous accompagne dès la réalisation de votre événement en tenant compte des contraintes d'espace, de temps et de budget de vos manifestations.

Need a showroom, shop, stand or sanitary block transportable, flexible and fast? ESW accompanies you from the realization of your event taking into account the constraints of space, time and budget.

► **Possibilités d'utilisation :**
Point de vente, stand d'exposition, boutique, billetterie, sanitaire pour événement, guichet de renseignement ...





Terrasse 18 m²



Terrasse 10 m²



Terrasse 6 m²



OPTIONS ET SERVICES

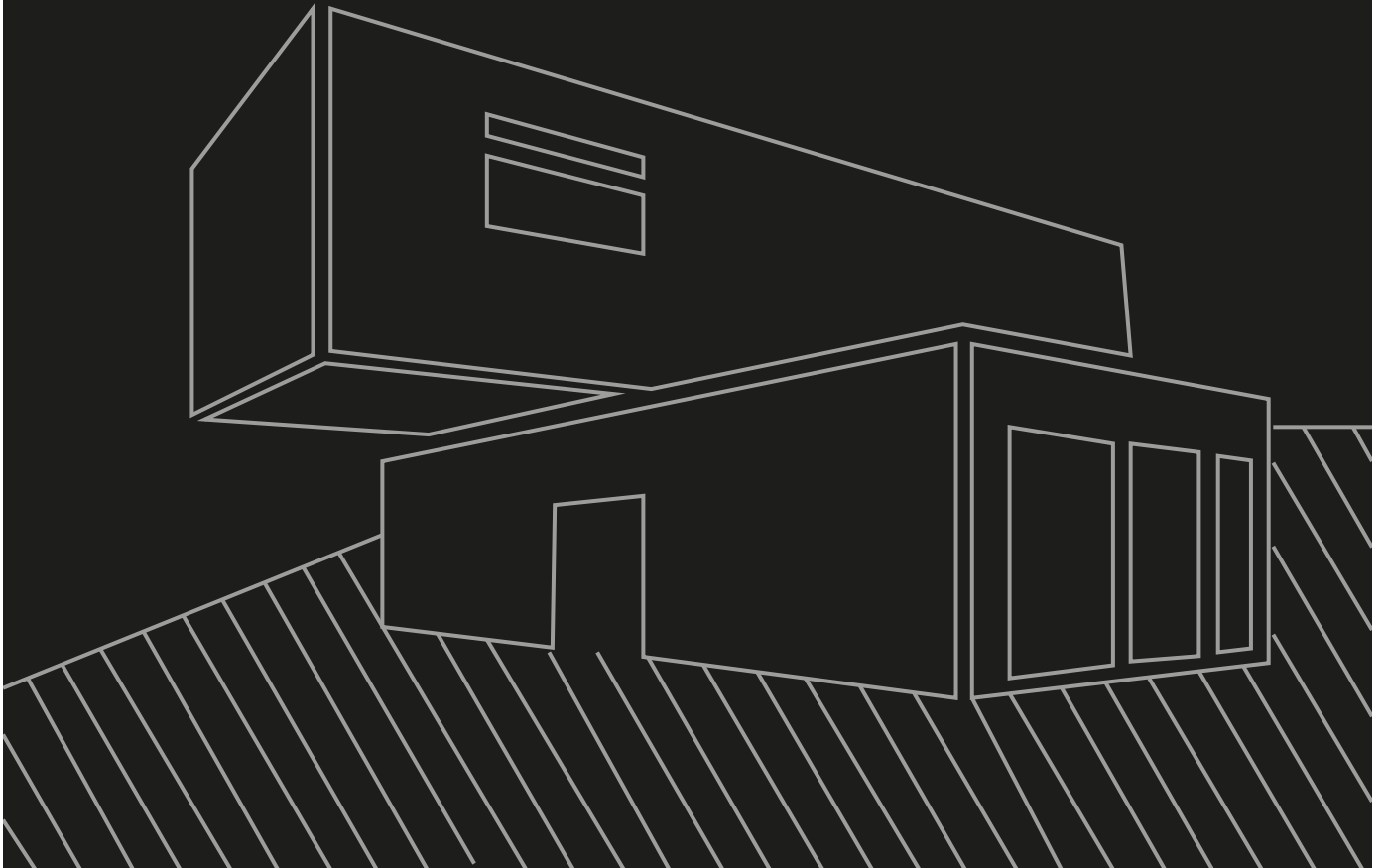

La solution clé en main !

ESW comprend vos besoins et transforme vos envies en réalité.

Equipez, décidez et assurez vos modules grâce à nos services intégrés : Mobiliers, Climatisation, Habillage, Vitrage, Sanitaire, Alarme...

The turnkey solution !

ESW understands your needs and turns your desires into reality. Equip, decorate and insure your modules thanks to our integrated services: Furniture, Air Conditioning, coating, Glazing, Sanitary, Alarm ...



TRANSPORT ET MANUTENTION





Nos solutions modulaires sont livrées clé en mains facilement par camion grâce aux réservations de passage de fourche ou aux anneaux de levage

Our modular solutions are delivered turnkey easily by truck thanks to forklift locks or lifting rings



CARACTÉRISTIQUES

STANDARD DE MODULES

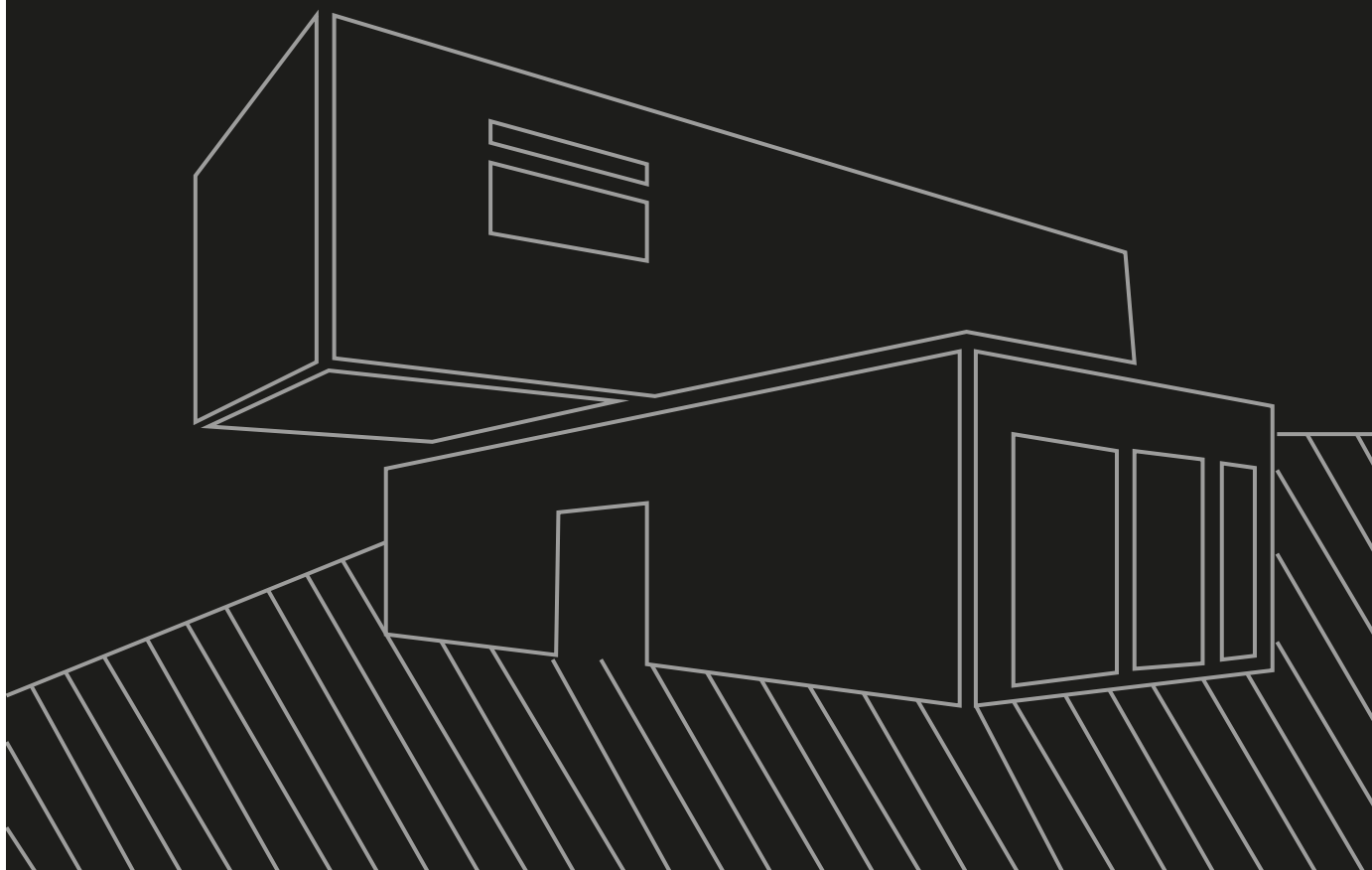



Légende

- 1 - Structure métallique : Profilés spéciaux en acier
- 2 - Panneau Sandwich : Isolation thermique et acoustique
- 3 - Plancher : Contre plaqué marin ép 18mm
- 4 - Toiture : Double toiture (panneaux sandwich et tôle ép 2mm)
- 5 - Menuiserie : Porte, fenêtre et baie vitrée en aluminium
- 6 - Installation électrique : Disjoncteur, luminaires, prises courant...
- 7 - Climatisation : Unité murale chaud-froid

Graph Legend

- 1 - Structure : special steel profiles
- 2 - Sandwich panels : thermal and acoustic insulation
- 3 - Floor : 18 mm thickness special plywood
- 4 - Roof : Double roof in sandwich panels and 2 mm sheet metal
- 5 - Joinery : Aluminium doors and windows
- 6 - Electrical installation
- 7 - Air conditioning

PARMI NOS RÉFÉRENCES

BTP



INDUSTRIE



COMMERCE ET SERVICES



ÉCOLES ET BANQUES



SERVICES PÉTROLIER



PUBLICS



BTP ETRANGER



AMBASSADES ET ORGANISATIONS INTERNATIONALES



**ILS NOUS ONT FAIT CONFIANCE, POURQUOI PAS VOUS ?
THEY TRUSTED US, WHY NOT YOU ?**



Créateur d'espaces modulaires

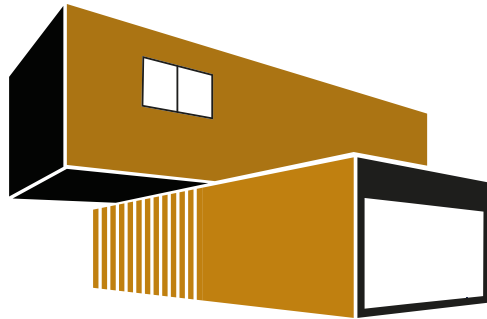

MODULE HOUSE

by  ESW

Contactez nous :

🏠 Z.I La Poudrière 2 - 3002 - Sfax - Tunisie 🌐 www.esw.tn ✉ commercial@esw.tn ✉ direction@esw.tn
☎ (+216) 74 215 758 / Fax : (+216) 74 239 068 / GSM : (+216) 20 326 719 📌 ESW- Ets Sellami Wahid

